

H. CASLER.
MUTOSCOPE.

(Application filed Feb. 4, 1896.)

(No Model.)

2 Sheets—Sheet 1.

Fig. 1

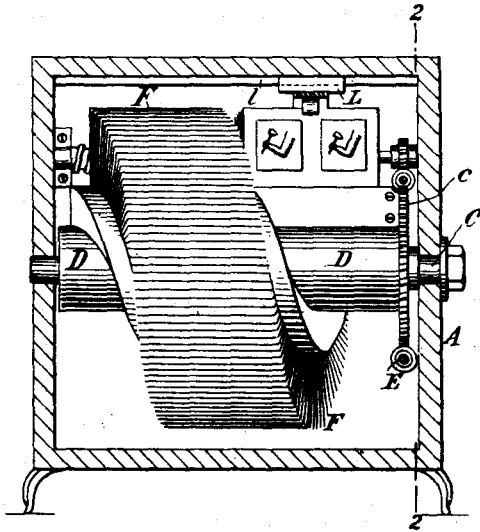

Fig. 2

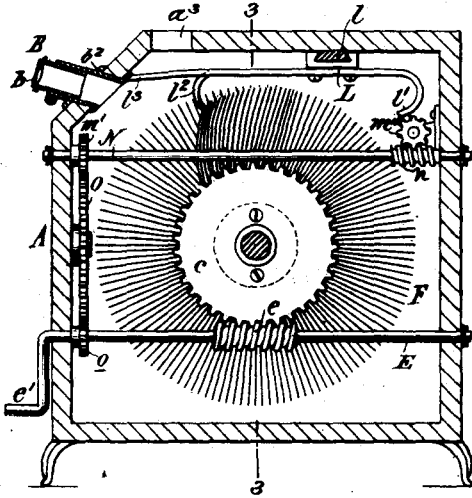
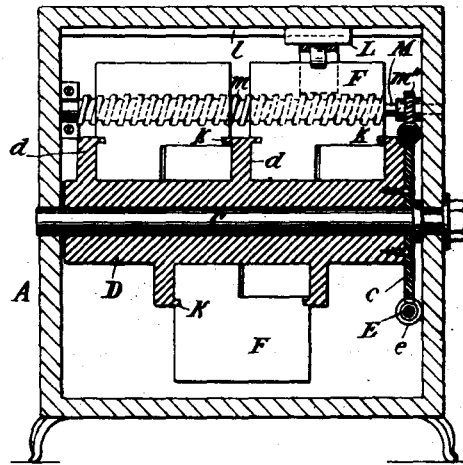

Fig. 3



Witnesses:
Raphael Ketter
M. A. Brown.

Herman Casler, Inventor
by Edmund Conger Brown, Atty.

H. CASLER.
MUTOSCOPE.

(Application filed Feb. 4, 1900.)

(No Model.)

2 Sheets—Sheet 2.

Fig. 4

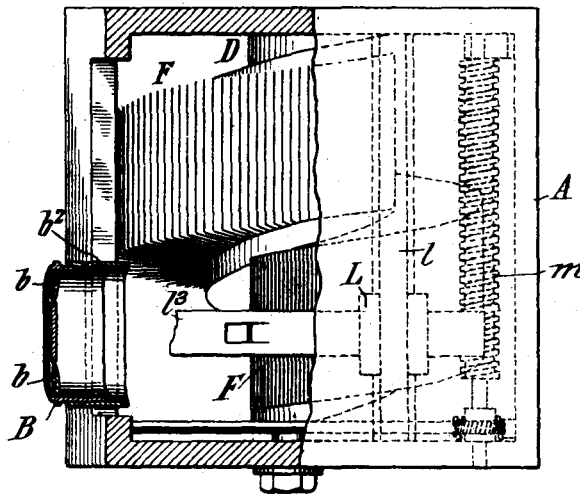

Witnesses:
Raphaël Ketter
Benjamin Miller

Herman Casler, Inventor
 by *Her. Page & Cooper, Attys.*

UNITED STATES PATENT OFFICE.

HERMAN CASLER, OF CANASTOTA, NEW YORK.

MUTOSCOPE.

SPECIFICATION forming part of Letters Patent No. 683,910, dated October 8, 1901.

Application filed February 4, 1896. Serial No. 577,974. (No model.)

To all whom it may concern:

Be it known that I, HERMAN CASLER, a citizen of the United States, and a resident of Canastota, in the county of Madison and State of New York, have invented certain new and useful Improvements in Mutoscopes, of which the following is a specification.

My invention relates to the class of devices for exhibiting consecutively-taken pictures of objects in motion, to which I have applied the name "mutoscope," the general construction and operation of which are now well understood in the art, having been described in Letters Patent granted to me on November 5, 1895, No. 549,309; and the principal object of this invention is to provide an apparatus particularly adapted for exhibiting a large number of pictures of objects in motion and for viewing the same by means of suitable magnifying-lenses, which are adapted to be moved laterally to follow the pictures.

The invention consists in the novel construction and combination of the parts of the apparatus, as hereinafter more particularly described.

In the accompanying drawings an apparatus is shown adapted for exhibiting stereoscopic pictures.

Figure 1 is an interior view of an apparatus constructed according to my invention. Fig. 2 is a vertical section taken on the line 2 2 of Fig. 1. Fig. 3 is a vertical section taken on the line 3 3 of Fig. 2, and Fig. 4 is a view showing the lenses and the devices which cause the same to travel laterally.

The working parts of an apparatus constructed according to my invention are inclosed in a box or casing A, which may be of any suitable form. A convenient shape is that shown in the accompanying drawings. Upon the diagonally-placed surface forming the front upper corner is borne an adjustable or telescopic support or fitting consisting of two parts B and b^2 for a pair of stereoscopic lenses b of the usual construction.

C is an arbor or shaft journaled in suitable bearings in the side walls of the casing A, so as to revolve freely, and provided at one end with a gear-wheel c , rigidly attached thereto. Upon the arbor C is placed a spool D, rigidly attached thereto and provided with a spiral elevation d , provided with inwardly-project-

ing rims k , as shown in Fig. 3. The picture-bearing cards F, which are substantially of the same form and construction as those now used in mutoscopes, except that they are somewhat wider to allow them to receive a pair of stereoscopic pictures instead of a single picture, are rigidly attached to the said spool D in a spiral row, as shown in Fig. 1.

As the construction of the picture-bearing cards and their various forms and modifications and the methods of securing the same to the spool are well understood in the art to which this invention relates I do not deem it necessary to here explain fully and in detail those features of the apparatus.

Suitably journaled in the walls of the casing A is a shaft E, bearing a worm e , adapted to engage with the gear-wheel c . The front end of the shaft E projects through the casing A and bears a crank e' , by means of which it may be revolved.

L is a bracket bearing a stop l^2 for the picture-bearing cards, as hereinafter described, and also provided with an extension-arm l^3 for conveying lateral motion to the stereoscopic lenses. The bracket L slides on a suitable trackway l in the top of the casing A, and the rear end of the bracket bears a pin or stud l' , adapted to engage with a worm m upon a shaft M, (see Fig. 3,) suitably journaled in the sides of the casing A, which shaft M bears at its end a gear-wheel m'' , which engages with a worm n (see Fig. 2) on a shaft N, suitably journaled in the front and rear walls of the casing A. This shaft bears a gear-wheel m' , which communicates, by means of an intermediate gear-wheel O, journaled in the front wall of the casing A, with a gear-wheel o on the shaft E.

The operation of my invention is as follows: Upon revolving the shaft E by means of the crank e' the worm e engages with the teeth of the gear-wheel c and causes the same, together with the arbor and its card-bearing spool, to revolve. The shaft also by means of the gear-wheel o revolves the wheels O and m' , the shaft N and its worm n , the gear-wheel m'' and its shaft M, and worm m . The worm m , acting on the pin or stud l' in the rear end of the bracket L, slides the bracket along its trackway. The bracket as it moves shifts the stereoscopic lenses laterally by means of its

arm \mathcal{B} , so that the said lenses are always directly in front of the picture-bearing card, which is at the time being held or checked momentarily by the stop \mathcal{B} . The various gears and worms are so proportioned and arranged that the lateral motion of the bracket L follows the spiral row of cards upon the spool. The rear end of the bracket L is slightly elastic, so as to enable the same to be disengaged from the worm and shifted back to its initial position after it has reached the end of its course, thus obviating the necessity of operating the machine backward to return the parts to their primary position. I do not, however, confine myself to this construction just described, as it is obvious that the same result may be attained by constructing the pin or stud so as to be removable from the rear end of the bracket.

For the purpose of obtaining access to the inside of the apparatus a portion of the casing is hinged, forming a door. Suitable openings in the casing are shown at a^3 , Fig. 2; but it is obvious that any suitable means of illuminating the pictures may be employed.

What I claim is—

1. In an apparatus for exhibiting a series of pictures, the combination of a shaft, a series of picture-bearing cards radially arranged thereon in a spiral line, means for supporting and revolving said shaft, and means for holding said cards in a position to be viewed, lenses for viewing said pictures and means for moving said lenses laterally with reference to the said shaft.

2. In an apparatus for exhibiting a series of pictures, the combination of a shaft, a series of picture-bearing cards radially arranged thereon in a spiral line, means for supporting and revolving said shaft, means for holding said cards in a position to be viewed, lenses for viewing said pictures and means for moving said lenses laterally with reference to the said shaft, comprising a worm-shaft and means for revolving the same, and a device adapted to engage with said worm and to be moved laterally thereby, one end of said device being operatively connected to the said lenses.

3. In an apparatus for exhibiting a series of pictures, the combination with a shaft, a series of picture-bearing cards radially arranged

thereon in a spiral line, means for supporting and revolving said shaft, means for holding said cards in a position to be viewed, of lenses for viewing said pictures and means for moving said lenses laterally with reference to the said shaft, comprising a shaft M bearing a worm m , a sliding bracket L, one end of which engages with the worm m and the other end of which is operatively connected to the said lenses, and means for revolving said shaft M.

4. An apparatus for exhibiting successively-taken pictures of moving objects, comprising a shaft having radially arranged thereon in a spiral line a series of cards bearing successively-taken pictures of objects in motion, lenses for viewing said pictures, means for revolving said shaft, means for momentarily checking the picture-bearing cards and holding them in a position to be viewed, means for moving said lenses laterally with reference to the said shaft and in a direction parallel to the axis of the same, comprising a worm-shaft and means for revolving the same, and a device adapted to engage with said worm and to be moved laterally thereby, one end of said device being operatively connected to the said lenses.

5. An apparatus for exhibiting successively-taken pictures of moving objects, comprising a shaft having radially arranged thereon in a spiral line a series of cards bearing successively-taken pictures of objects in motion; lenses for viewing said pictures, means for revolving said shaft, means for momentarily checking the picture-bearing cards and holding them in a position to be viewed, means for moving said lenses laterally with reference to the said shaft, comprising a shaft M bearing a worm m , a sliding bracket L, one end of which engages with the worm m and the other end of which is operatively connected to said lenses, and means for revolving said shaft M.

Signed at Canastota, in the county of Madison and State of New York, this 31st day of January, A. D. 1896.

HERMAN CASLER.

Witnesses:

H. D. MARVIN,
C. F. BARLOW.